

PARABODY

Serious Steel

914101 ST PLATE RACK

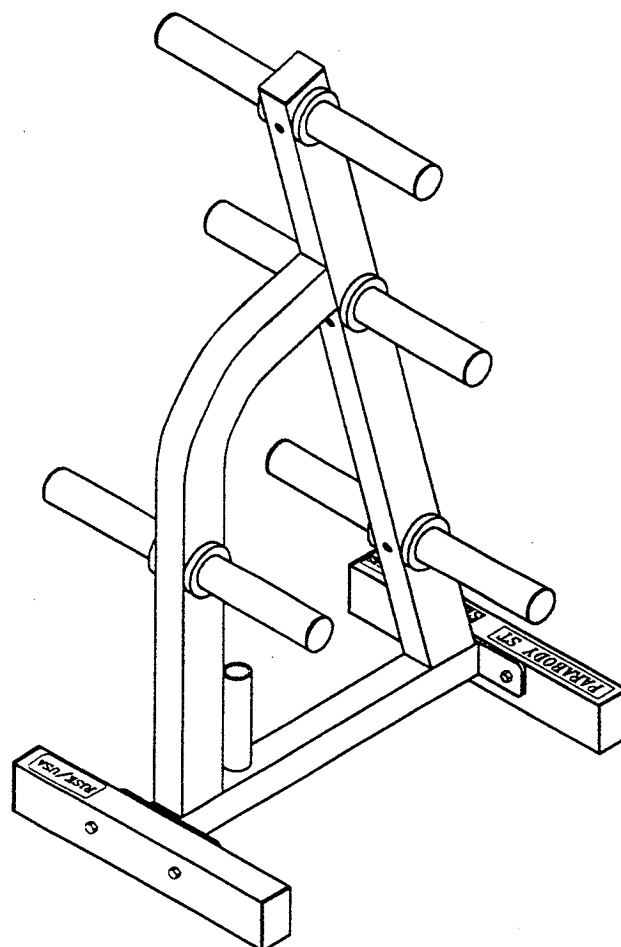

ASSEMBLY INSTRUCTIONS

IMPORTANT NOTES

There is a risk assumed by individuals who use this type of equipment. To minimize risk, please follow these rules:

1. Consult your physician before beginning any exercise program.
2. Inspect equipment daily. Tighten all loose connections and replace worn parts immediately. Failure to do so may result in serious injury.
3. Do not allow minors or children to play on or around this equipment.
4. Exercise with care to avoid injury.
5. If unsure of proper use of equipment, call your local Parabody distributor or call the Parabody customer service department at (800) 328-9714.

Please note:

- * Thank you for purchasing the Parabody 914101 ST PLATE RACK. Please read these instructions thoroughly and keep them for future reference. This product must be assembled on a flat, level surface to assure its proper function.
- * We recommend cleaning your product (pads and frame) on a regular basis, using warm soapy water. Touch-up paint can be purchased from your Parabody customer service representative at (800) 328-9714.

Tools Required for Assembly

- * 3/4" wrench
- * Ratchet with 3/4" socket
- * Tape measure
- * 7/32 Allen wrench

Bolt Length Ruler

NOTE: BOLT LENGTH IS MEASURED FROM THE UNDERSIDE OF THE HEAD OF THE BOLT.

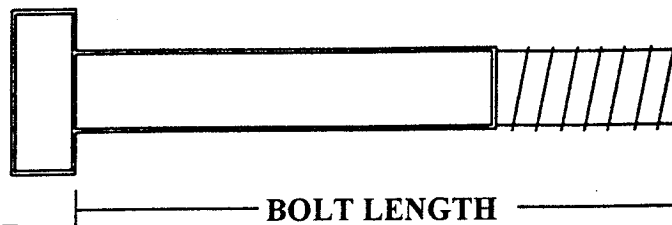

BOLT LENGTH RULER:

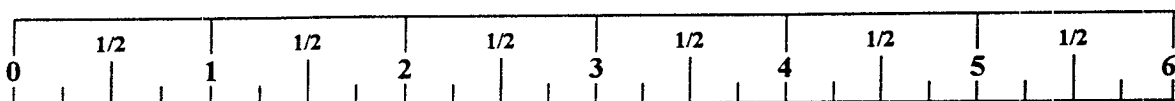

PARTS LIST

KEY	PART #	DESCRIPTION	QTY
1	6690101	FRAME WELDMNT	1
2	6690401	1-1/2" DIA X 19" TUBE	4
3	3102502	3/8" LOCKWASHER	4
4	3102910	1/2 X 3" BOLT	4
5	3102801	1/2" LOCKNUT	4
6	3102502	RUBBER BUMPER	8
7	3102502	1/2" FLAT WASHER	4
8	3202401	3/8 X 1" BUTTON HEAD CAP SCREW	4
9	6615503	3 X 2 X 18" TUBE	2

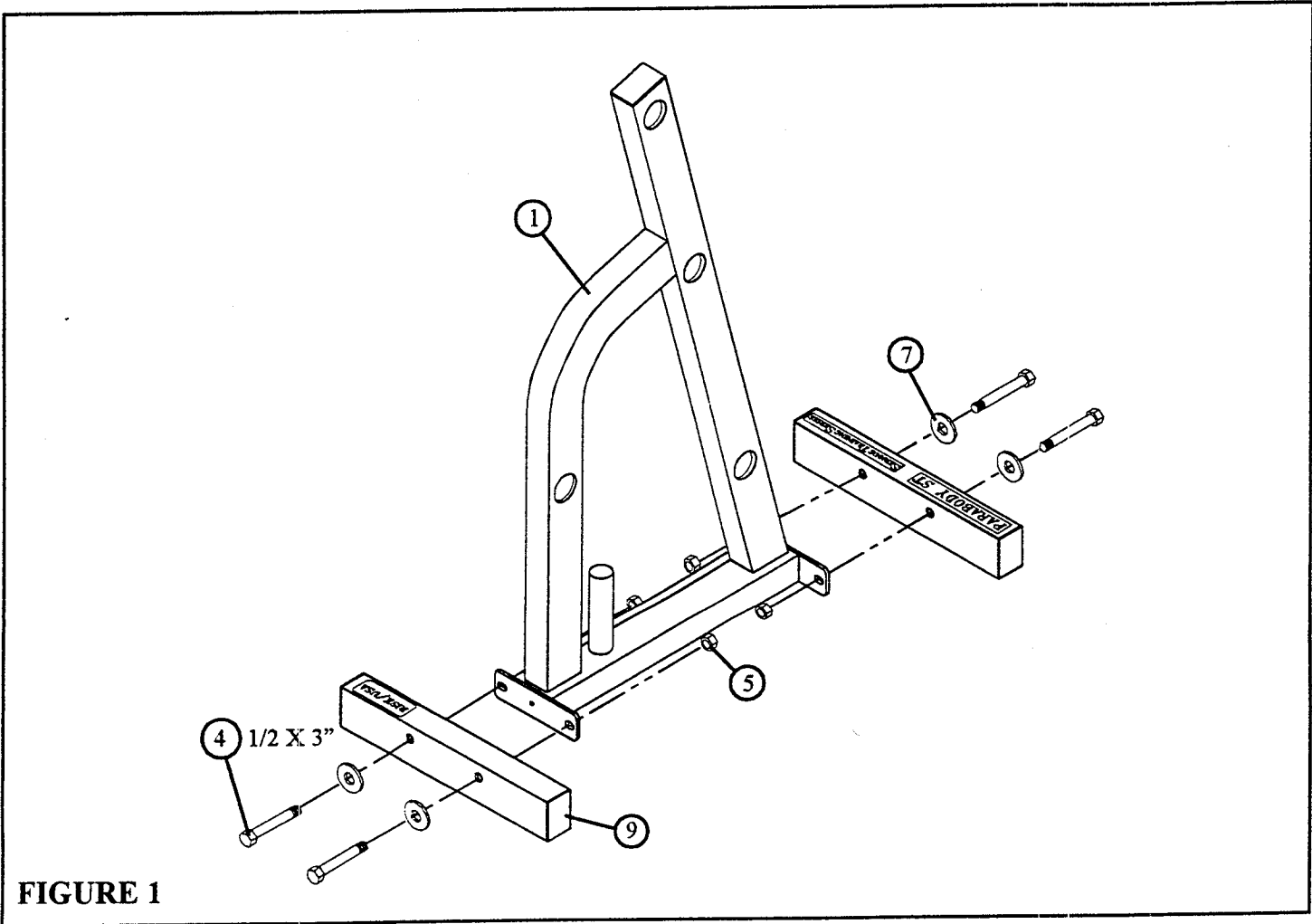
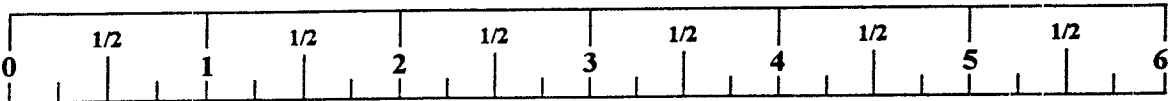

FIGURE 1

STEP 1: SECURELY assemble two 3 X 2 X 18" TUBES (9) to the FRAME WELDMT (1) using four 1/2 X 3" BOLTS (4) four 1/2" FLAT WASHERS (7) and four 1/2" LOCKNUTS (5) as shown in FIGURE 1.



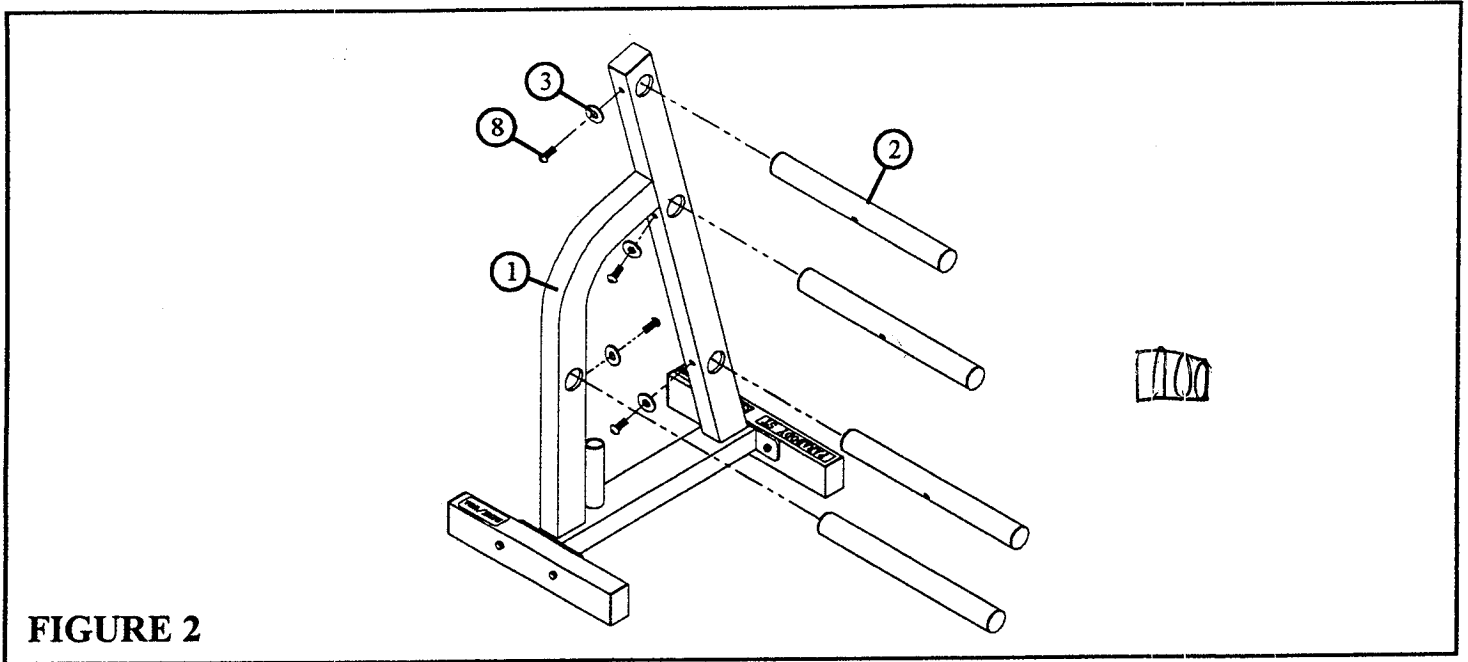

FIGURE 2

STEP 2: Insert the four 1-1/2 DIA X 19" TUBES (2) through the side of FRAME WELDMENT (1) so the threaded hole in the 19" TUBES (2) lines up with the holes in the FRAME WELDMENT (1) as shown in FIGURE 2.

STEP 3: SECURELY assemble the four 1-1/2" DIA X 19" TUBES (2) to the FRAME WELDMENT (1) using four 3/8-16 X 1" BUTTON HEAD CAP SCREWS (8) and four 3/8" LOCKWASHERS (3) as shown in FIGURE 2.

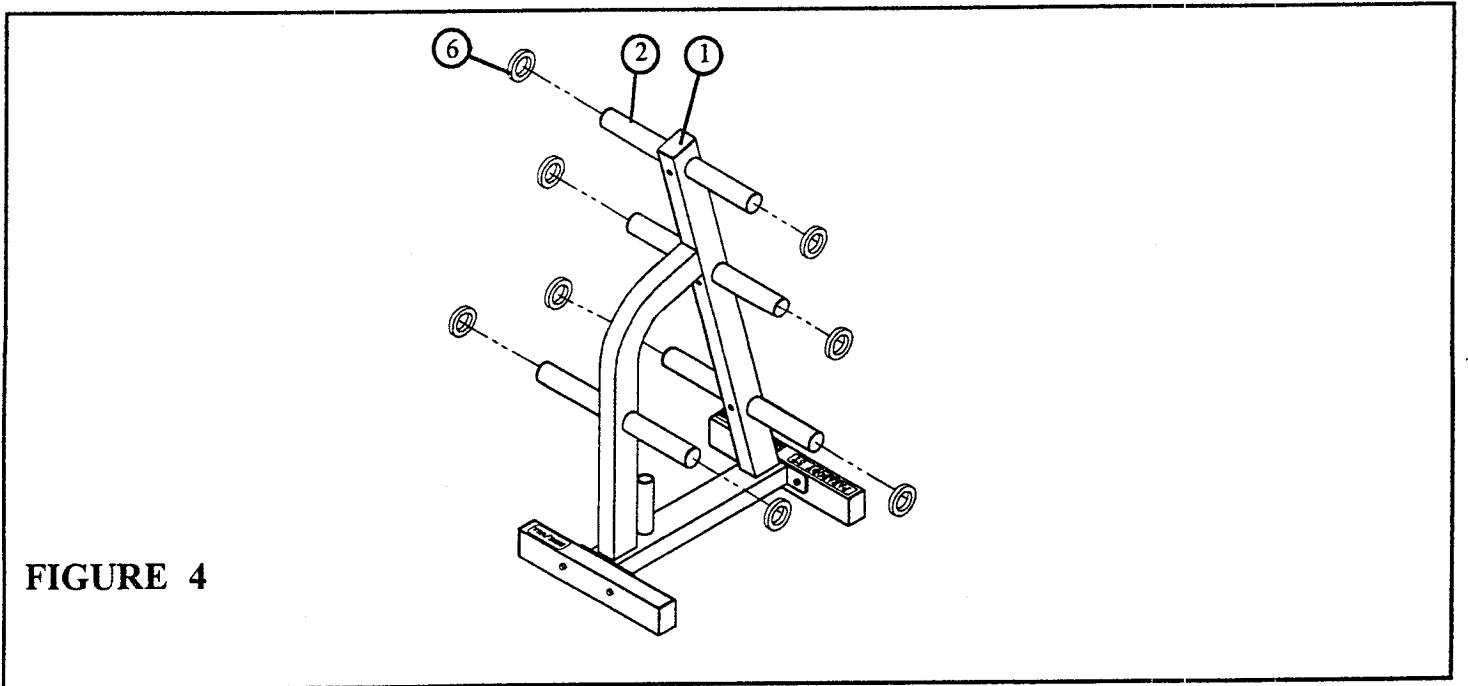

FIGURE 4

STEP 4: Slide eight RUBBER BUMPERS (6) over the ends of the 1-1/2" DIA X 19" TUBES (2) and up against the FRAME WELDMENT (1) as shown in FIGURE 4.

